

CAD FILE:

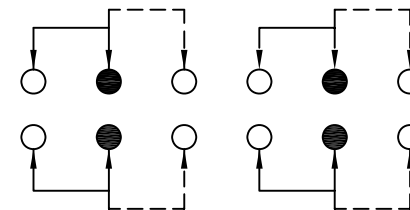

SCHEMATIC (SHORTING)

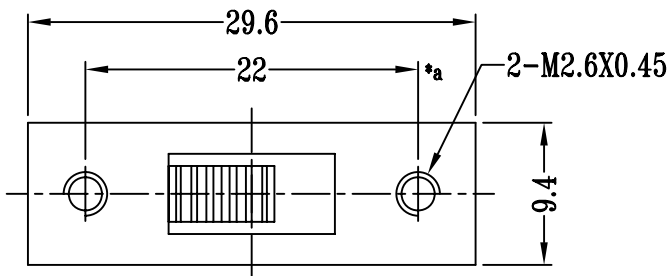
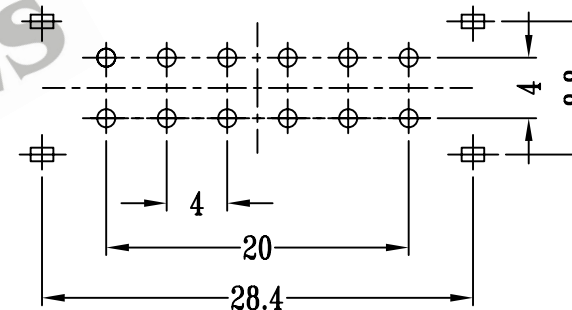
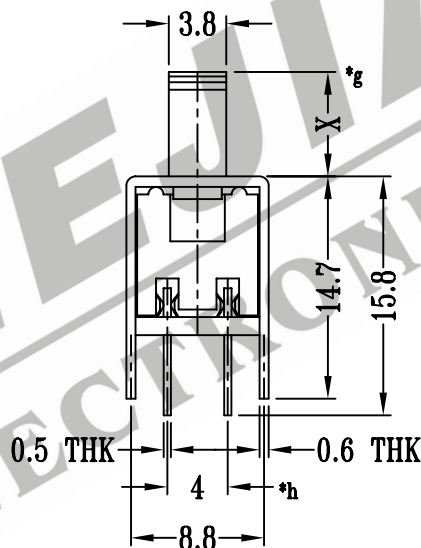
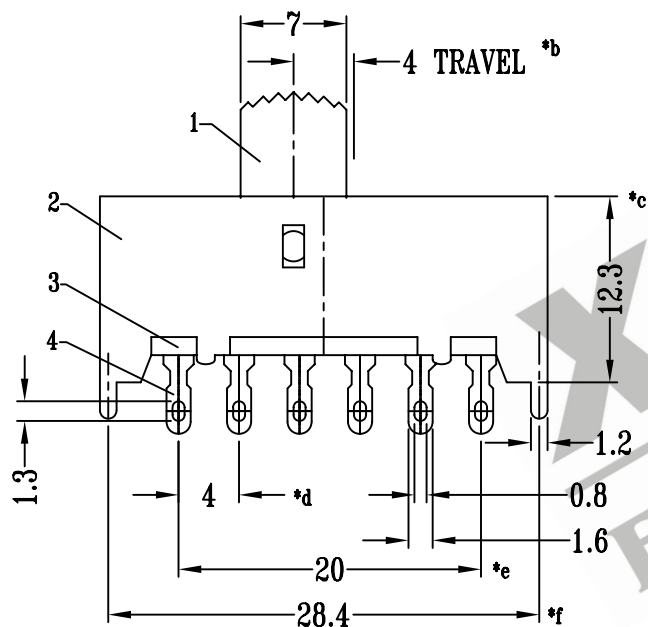

P.C.B LAYOUT

注:带"\*"表示关键尺寸(8个)

					TOLERANCE UNLESS SPECIFIED		SHENZHEN XIEJIA ELECTRONICS CO.,LTD.				
					WITHIN: 1.5±0.1mm		ISSUE	DATE	DESCRIPTIONS		APPD.
					OVER : 1.5±0.2mm				TITLE : VERTICAL SLIDE SWITCH		
8									DRWG NO.: XJ-DR-SS42H24-00		
7	CONTACT CLIP	PBS STRIP	4	Ag PLATED					DWN.	ZHOUYU	2006-12-20
6	STEEL BALL	STEEL	2	NATURAL					CHK'D	FANGYING	2006-12-20
5	SPRING	STEEL WIRE	1	TEMPER					APPD.	KANGXINAN	2006-12-20
4	TERMINAL	BRASS STRIP	12	Ag PLATED OVER Ni PLATED	TITLE : VERTICAL SLIDE SWITCH		UNIT : MM		DRWG NO.: XJ-DR-SS42H24-00		
3	BASE	PHENOLIC RESIN	1	BLACK	MODEL: SS42H24		SCALE: 2:1		DWN.	ZHOUYU	2006-12-20
2	FRAME	STEEL STRIP	1	Ni PLATED	ALL MATERIALS MUST BE COMPLIANT TO ROHS				CHK'D	FANGYING	2006-12-20
1	KNOB	POM	1	BLACK					APPD.	KANGXINAN	2006-12-20
NO.	PART NAME	MATERIAL	Q'TY	FINISHING							